



### Performance

Voltage	12V
Capacity (20-hour)	100Ah
Cold Cranking Amps (EN1)	800A
Reserve Capacity	190 min

### Dimensions

Length	330mm
Width	170mm
Height	217mm
Total Height	240mm

### Weights & Measures

Mean Weight with Acid	24.0kg/52.91lbs
Dry Weight	-
Acid Volume	1.30±0.015g/cm3 (25ℓ)



### Container Features

Case Type	31M BCI Group	Flame Arrestor	✓
Cell Layout	1	Technology	Ca/Ca
Hold Down	B0	Separator	PE
State of Charge Indicator	✓	Vibration	V1 (30Hz/3g/2hr)
Handles	✓	Recommended Charge Rate	5A
End Venting	✓	Case	Black-PP Material
Semi-Traction Features	✓	Cover	Black-PP Material
Lid Type	SMF Double Lid	Handle	Black-PP Material

### Terminal Type

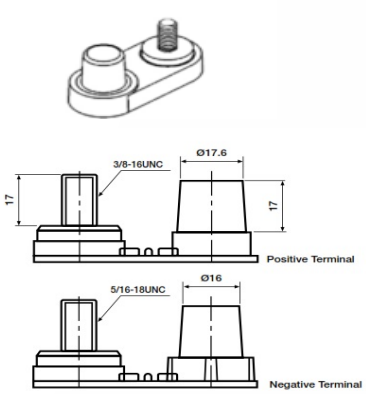

### Cell Assembly Layout

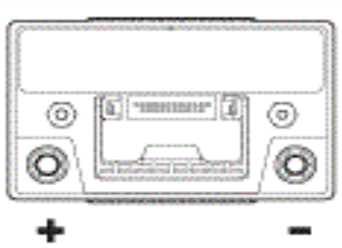

### Battery Hold-down

