

BANSHEE™

MARINE BATTERY

BCI GROUP 34M

Performance

Voltage	12V
Capacity (20-hour)	66Ah
Cold Cranking Amps (EN1)	750A
Reserve Capacity	100 min

Dimensions

Length	260mm
Width	175mm
Height	200mm
Total Height	220mm

Weights & Measures

Mean Weight with Acid	16.8kg/37.03lbs
Dry Weight	-
Acid Volume	4.30±0.015g/cm ³ (25°C)



Container Features

Case Type	34M BCI Group	Flame Arrestor	✓
Cell Layout	1	Technology	Ca/Ca
Hold Down	B0	Separator	PE
State of Charge Indicator	✓	Vibration	V1 (30Hz/3g/2hr)
Handles	✓	Recommended Charge Rate	5A
End Venting	✓	Case	Black-PP Material
Semi-Traction Features	✓	Cover	Black-PP Material
Lid Type	SMF Double Lid	Handle	Black-PP Material

Terminal Type

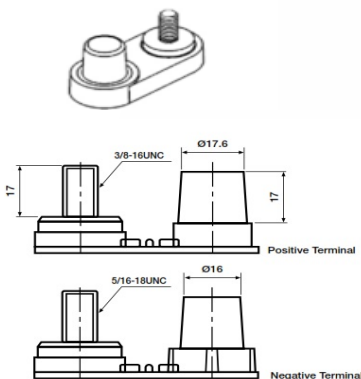

Cell Assembly Layout

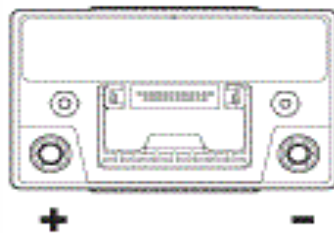

Battery Hold-down

