

PowerStar PS30L-BS

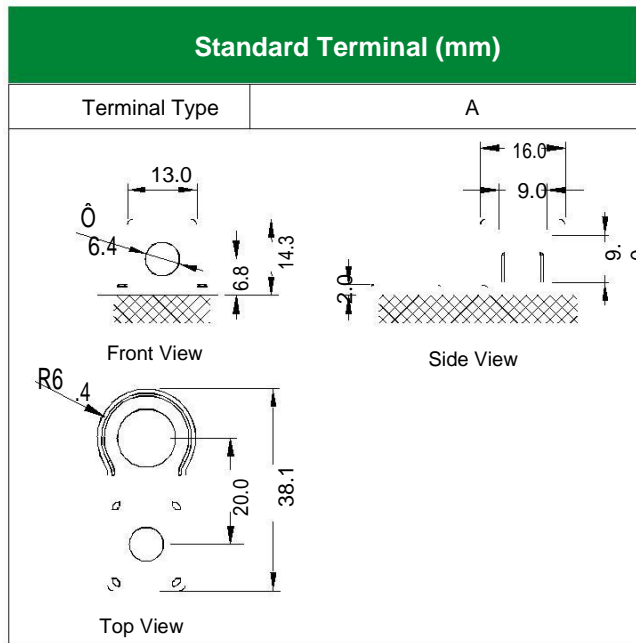
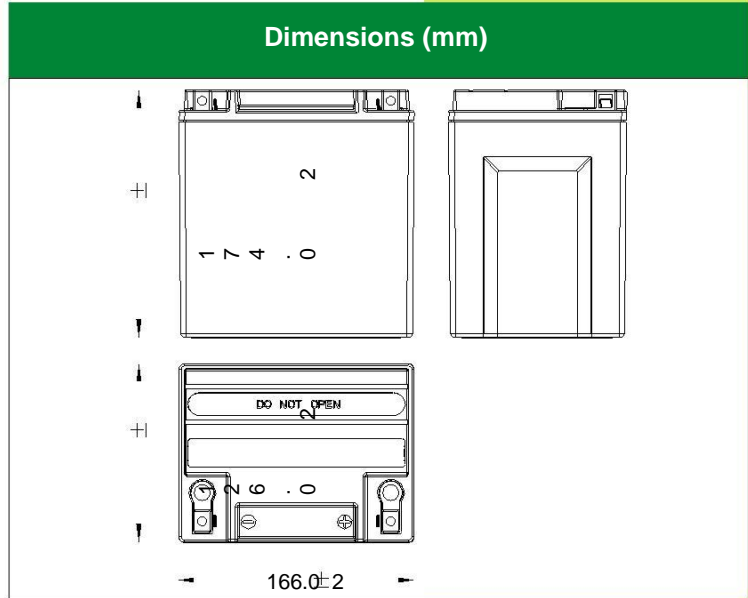

Physical Specification

Nominal Voltage	12V	
Nominal Capacity (10HR)	30AH	
Dimension	Length	166 ± 2mm (6.54 inches)
	Width	126 ± 2mm (4.96 inches)
	Container Height	174 ± 2mm (6.85 inches)
	Total Height (with Terminal)	174 ± 2mm (6.85 inches)
Weight	Battery(with acid): Approx 9.94kg (21.89lbs)	
	Electrolyte: Approx 1.91kg (4.21lbs)	

- * Sealed and non-spillable AGM battery
- * Maintenance-free
- * Powerful 385 cold cranking amps
- * Shipped pre-charged and ready to install
- * Replaces / upgrade for EB30-3

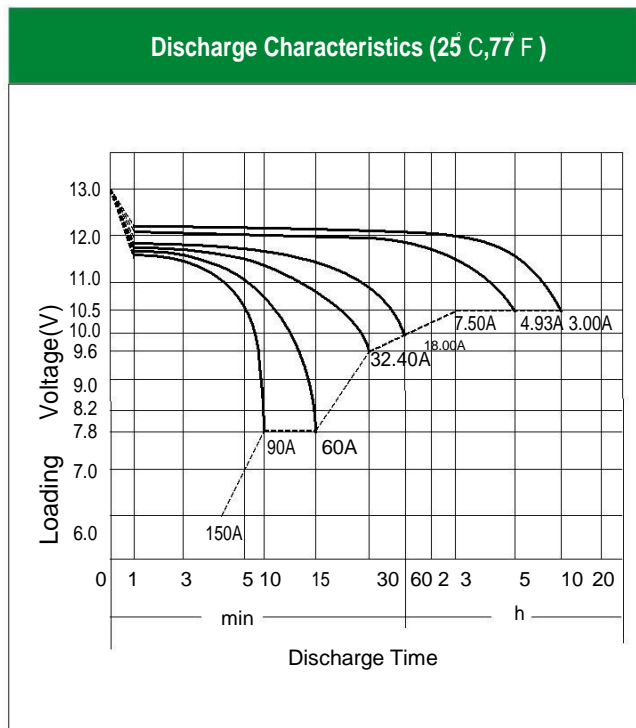

Electrical Specification

Rated Capacity	10 hour rate (3.00 A)	30.00AH
	5 hour rate (4.93 A)	24.60AH
	2 hour rate (10.5 A)	21.00AH
	1 hour rate (18.0 A)	18.00AH
	0.5 hour rate (32.4 A)	16.20AH
Capacity affected by Temperature	40°C (104°F)	106%
	25°C (77°F)	100%
	0°C (32°F)	86%
	-15°C (5°F)	65%
Self Discharge	Approximately 3% per month (25°C (77°F))	
Charging Methods	Full Charge	Constant-Voltage Charge: Initial charging current: less than 9.0A Voltage: 14.40 V ~ 15.00 V at 25 °C (77 °F) Charging time: 15 ~18h Constant-Current Charge: Charging current: 0.1C ₁₀ =3.00A, when charging voltage up to 14.40V, continue to charge 4h No limit on Initial charging current
		Floating Charge Voltage: 13.50 V ~ 13.80 V at 25 °C (77 °F)