

PowerStar PS-YB9L-B

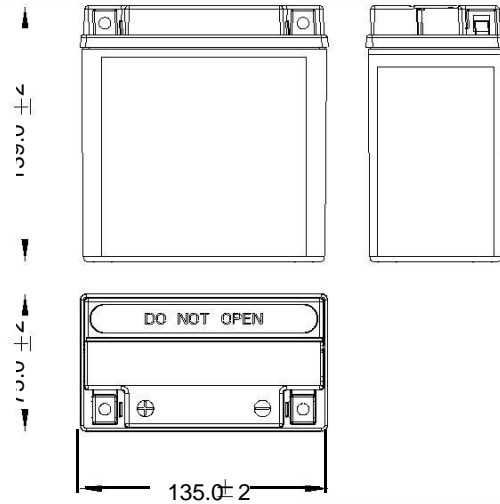

Dimensions (mm)



Standard Terminal (mm)

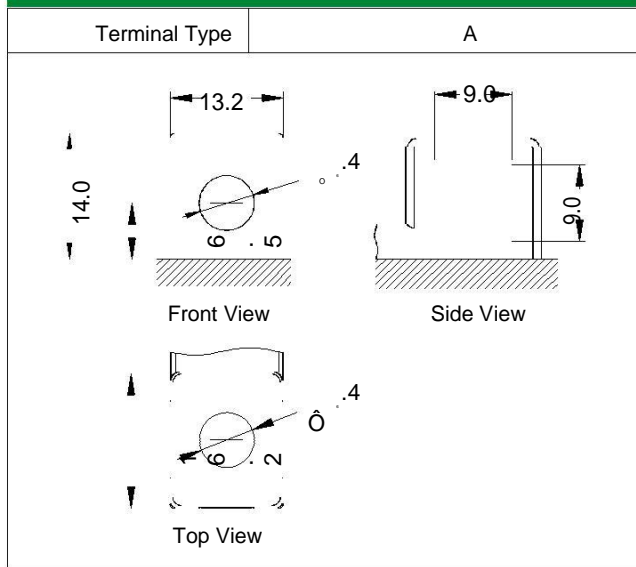

Physical Specification

Nominal Voltage	12V	
Nominal Capacity (10HR)	9AH	
Dimension	Length	135 ± 2mm (5.31 inches)
	Width	75 ± 2mm (2.95 inches)
	Container Height	139 ± 2mm (5.47 inches)
	Total Height (with Terminal)	139 ± 2mm (5.47 inches)
Weight	Battery(with acid):	Approx 3.20g (7.05lbs)
	Electrolyte:	Approx 0.65kg (1.43lbs)
<ul style="list-style-type: none"> * Sealed and non-spillable AGM battery * Maintenance-free * Powerful 120 cold cranking amps * Shipped pre-charged and ready to install * Replaces / upgrade for EB9A-4 		

Discharge Characteristics (25 °C, 77 °F)

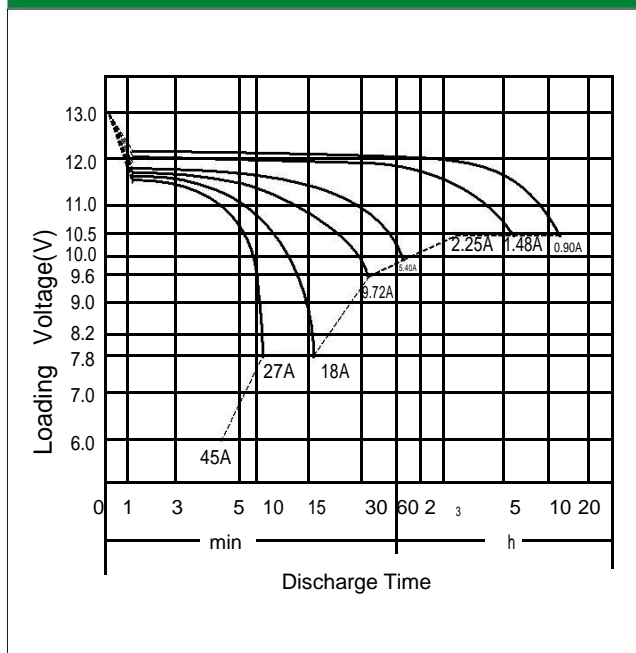

Electrical Specification

Rated Capacity	10 hour rate (0.90 A)	9.0AH
	5 hour rate (1.48 A)	7.38AH
	2 hour rate (3.15 A)	6.30AH
	1 hour rate (5.40 A)	5.40AH
	0.5 hour rate (9.72 A)	4.86AH
Capacity affected by Temperature	40 °C (104 °F)	106%
	25 °C (77 °F)	100%
	0 °C (32 °F)	86%
	-15 °C (5 °F)	65%
Self Discharge	Approximately 3% per month (25°C (77°F))	
Charging Methods	Full Charge	Constant-Voltage Charge: Initial charging current: less than 2.7A Voltage: 14.40 V ~ 15.00 V at 25 °C (77 °F) Charging time: 15 ~18h Constant-Current Charge: Charging current: 0.1C ₁₀ =0.90A, when charging voltage up to 14.40V, continue to charge 4h
	Floating Charge	No limit on Initial charging current Voltage: 13.50 V ~ 13.80 V at 25 °C (77 °F)